

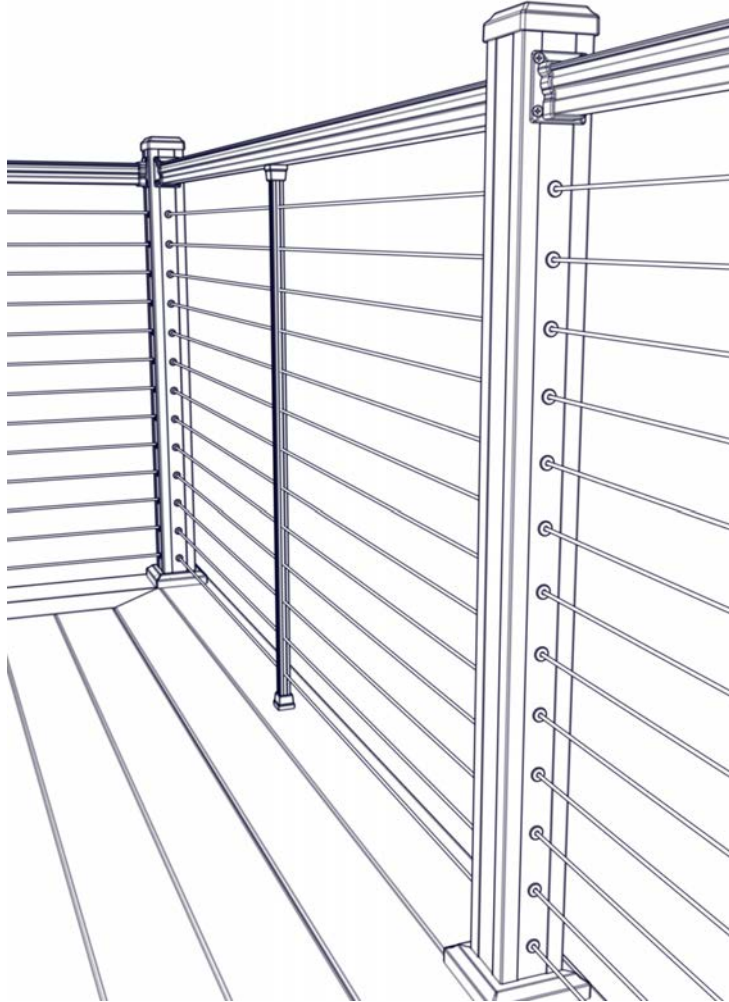

# HORIZONTAL CABLE INFILL

American & Arabian Series

\*Reference Local Building Codes for Railing and Cable Installation requirements



## What's Included

- Top Rail & Baluster(s)
- Mounting Brackets & Screws  
*(Predrilled Posts, Caps, & Trim packaged separate)*
- Stainless Steel Cable Roll *(optional)*

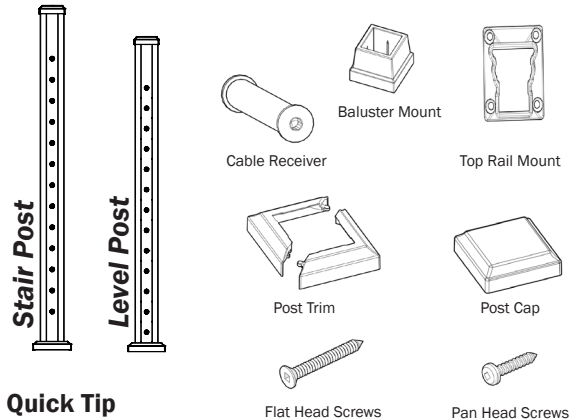

### Quick Tip

Wear clean, new gloves when handling stainless steel parts to prevent corrosion from oil and dirt.

## Recommended Tools

- Safety Glasses
- Tape Measure & Pencil
- Level
- Drill & Bits ( $\frac{1}{4}$ " ,  $\frac{3}{16}$ " ,  $\frac{1}{32}$ " )
- Hammer Drill (if concrete)
- Circular Saw w/ Fine-Tooth Aluminum Cutting Blade
- Rubber Mallet

- Available from Key-Link

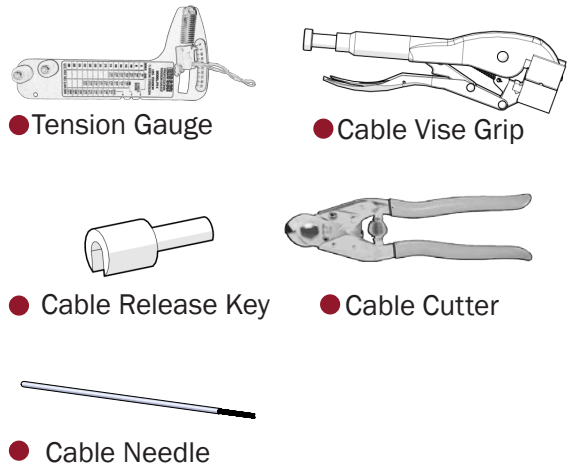

- These directions are only a guide and may not address every situation.
- Always wear proper safety equipment while assembling and installing.
- The installer should obtain all required building permits and follow all installation procedures in accordance with applicable building code requirements.
- Key-Link Fencing and Railing Inc. shall not be held liable for improper or unsafe installations.
- Applying paint, other than Key-Link's touch up paint, will void your warranty.
- To ensure proper coverage by our warranty please visit our website and complete the warranty form and mail to: Key-Link Fencing & Railing, Inc., 150 Orlan Road, New Holland, PA 17557

# Post, Baluster, and Top Rail Installation

## 1 Install Railing Post & Post Trim

Space Posts according to \*application and Top Rail length. A structural member must be placed between top of Posts to ensure proper cable tensioning. Place leveling plate (*highlighted*) between Post and mounting surface.

Attach to structural surface using bolts or lags (*not included*). Partially Tighten prior to levelling. Using  $\frac{3}{16}$ " Allen wrench, turn set screws to level Post. Then fully tighten structural screws.

*\*Check your local building codes to determine structural mounting requirements for Post.*

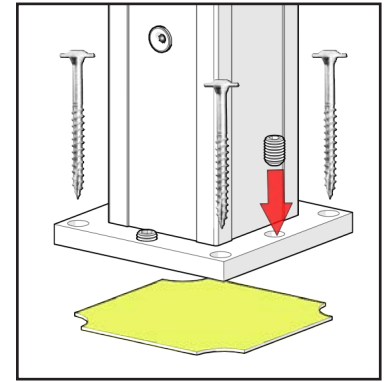

## 2 Attach Baluster Mount

*\*(If Needed) Cut Rail to proper length*

Attach a Baluster Mount (*circled*) centered on the bottom surface of the Top Rail and another to the deck aligned with the baluster mount on the Top Rail. Fasten the Baluster to the Mount.

### Baluster Spacing

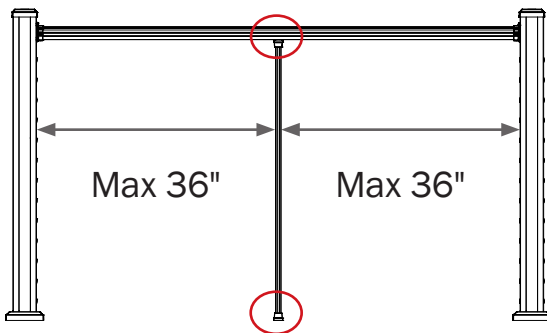

*Balusters should be spaced evenly and no more than 36" apart*

### ! Cutting Tip

Be sure to use a **fine-tooth blade approved for cutting aluminum** and rest rails on a piece of **non-abrasive material** to protect from scratches.

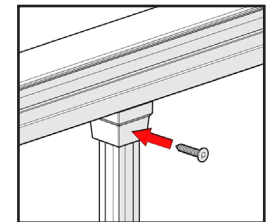
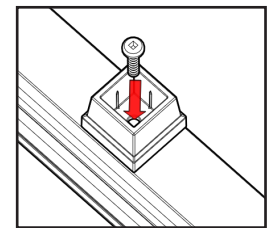

## 3 Attach Top Rail

Slide the Bracket over the Rail, then put the Rail in place, and slide the self-centering Bracket against the Post. Fasten Bracket to Post using #12 screws, and secure Bracket to Rail using #10 pan-head screws.

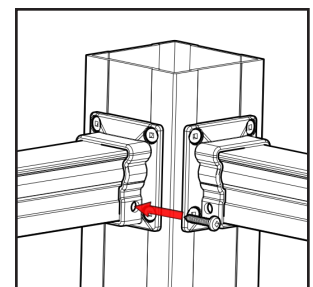
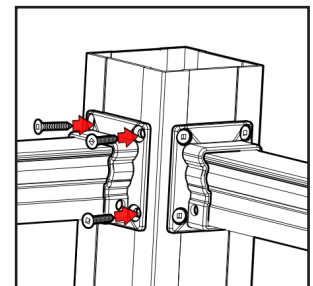

# Cable Rail Installation

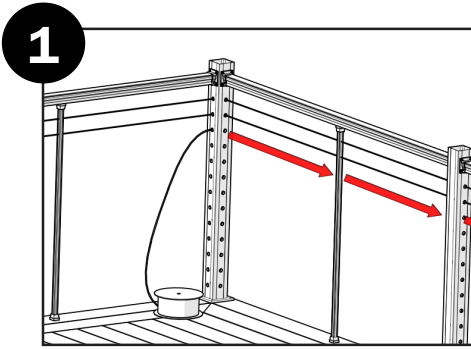

Thread the cable through all the Posts and balusters starting from one end Post to the next end Post.

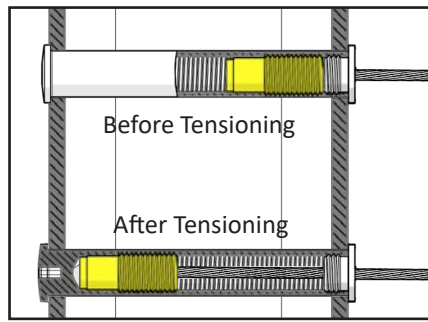

Check to make sure the Lock Jaw housing (*highlighted*) is threaded all the way out to the cap to maximize tensioning capacity.

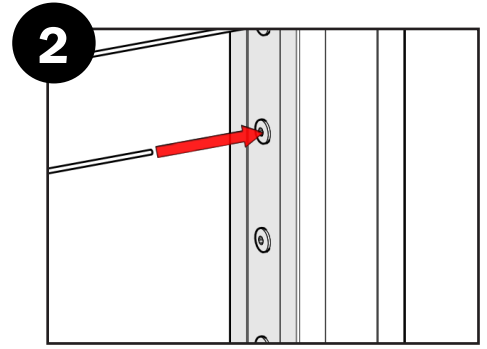

Insert the cable into the end Post Receiver as far as it will go. Gently twist clockwise on the cable to until it is secure.

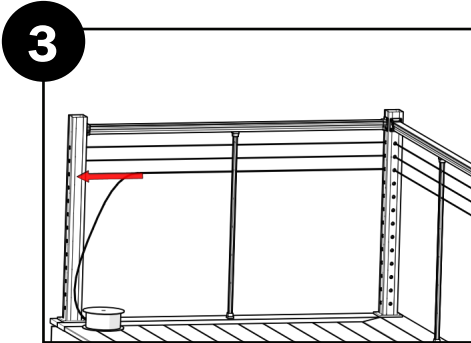

Unwind enough cable to reach to the opposite end Post and pull tight. Removing all slack from each section.

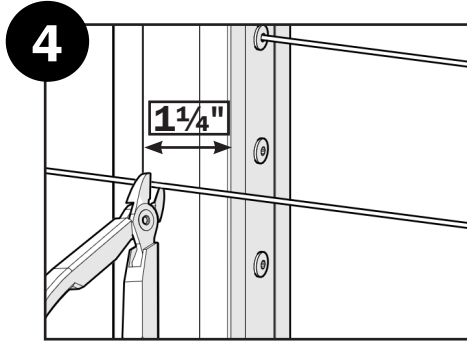

Remove Cable Slack and cut  $1\frac{1}{4}$ " longer than inside face of the end Post Receiver. Insert Cable into the Receiver in a clockwise direction. (*Optional use Cable Vice Grip Tool*)

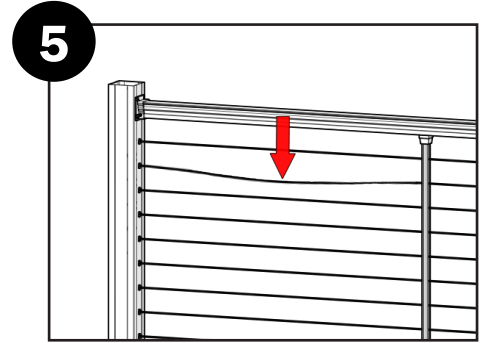

Once both cable ends have been inserted; place body weight onto each cable to set/anchor them firmly inside Receivers. (*Before continuing to Step-7*) Repeat previous steps for the remaining Post and Baluster rows.

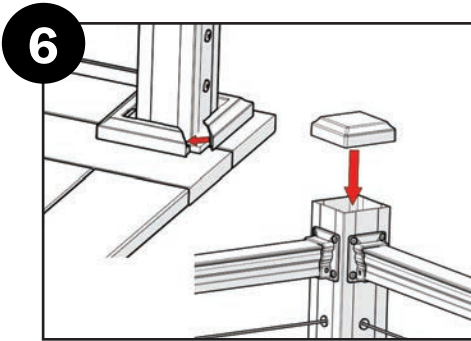

Place Post Cap on Post and use soft or rubber mallet to set in place. Snap the Post Trim halves together around the bottom of each Post.

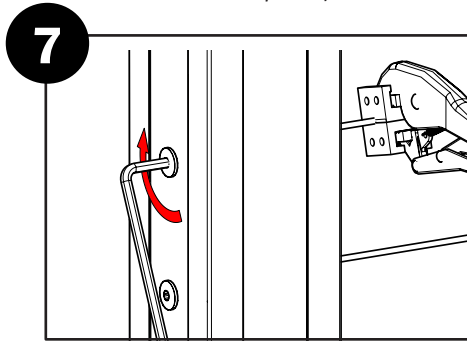

Use a  $\frac{3}{16}$ " Allen Wrench, to tighten  
**Tip: Tighten every other row first, working away from the center.**

A Tension Gauge (*available from Key-Link*) can be used to tighten the cable to the desired tension.

When tightening cable; watch to ensure the cable is not spinning which could indicate the receiver is fully tightened.

**Do not overtighten!**

**Cable can release if over tightened**

Check with your local building inspector about local codes regarding cable tension.

## Cable Release Key

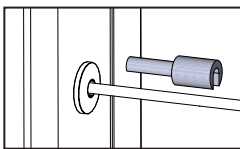

To use the **Cable Release Key**, slide it over the

cable into the receiver, and push to release the cable. For use before the cable is fully tightened.

## Cable Needle

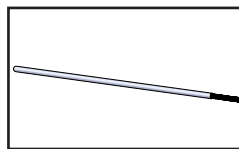

The **Cable Needle** is used for

threading the cable through balusters & posts that do not have fittings.

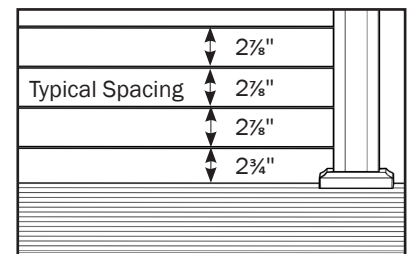

Check with your local building inspector on how close the cables should be if drilling the Post yourself.

# Stair Rail Installation

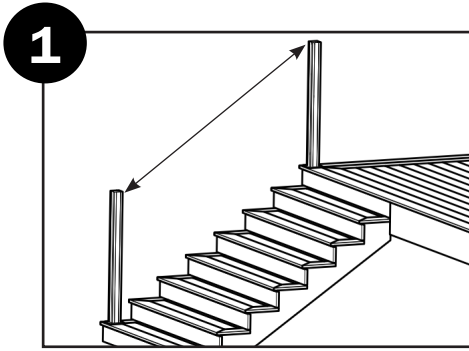

1 Measure from inside edge between Posts (then subtract ¼")

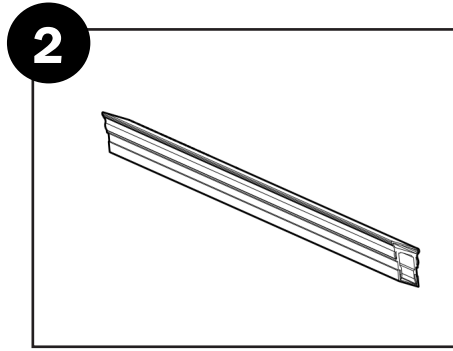

2 Cut Upper and Lower ends of Top rails at opposite angles. To ensure Rails align properly. (Standard stair angle is 34°)

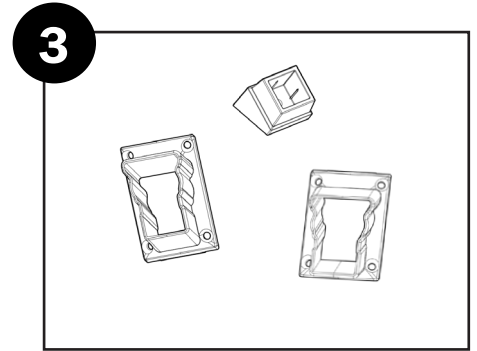

3 Attach both Baluster stair mounts, and Up and Down Top rail mount (Refer to pg.2 Step 2 & 3)

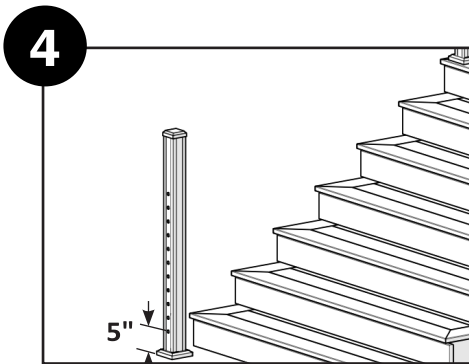

4 On stairs; use the Post with 5" spacing to the bottom receiver. Standard Posts can only be used on stairs when stair angle is 34°. For all other angles, blank Posts will need to be used and custom drilled.

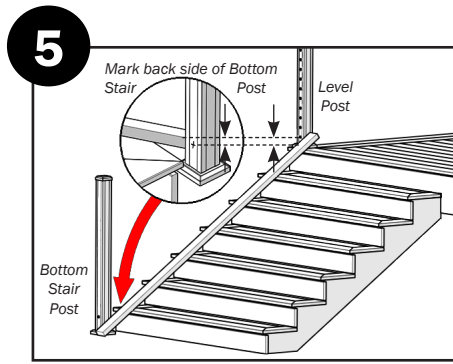

5 To determine first hole placement; use a straight edge laid flat on the nose of the stairs, and measure off the surface to the first hole on the Level Post, and translate that measurement to each Post/ Baluster.

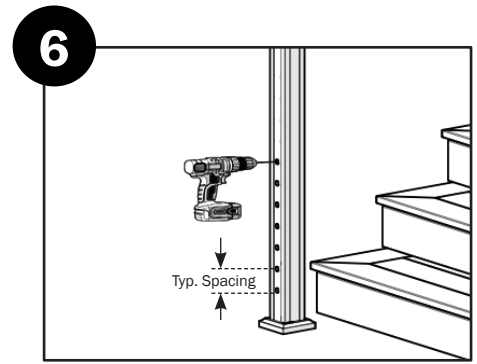

6 Use typical spacing (2¼") to mark each additional hole on both sides of the Bottom Stair Post, and drill a 1½" level hole at each mark.

**Note:** On a Line Post, or Baluster; ⅜" holes should be drilled at the appropriate stair angle.

**!** When doing stair sections, mount them as shown below:

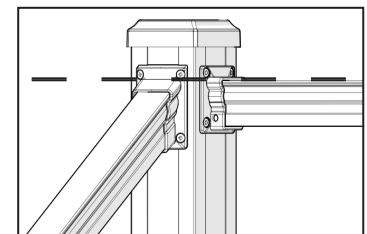
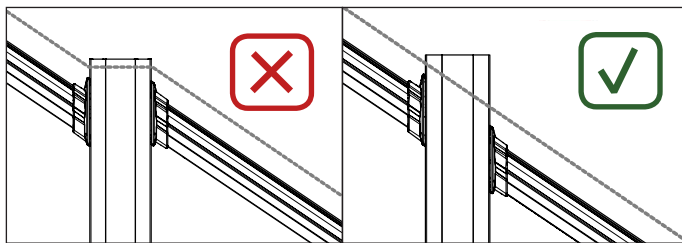

Ensure that the stairs' Top Rail doesn't exceed the level rail height of the opposite Rail.

**!** **NOTE: How to Loosen Stuck Jaws**

In the event that the jaws of the post receiver become stuck.

Insert an Allen Wrench into the open end of the cable receiver, and press until you can feel the internal spring release.



150 Orlan Road • New Holland, PA 17557

KeyLinkOnline.com